

NOTE ON OBLIQUE EXCHANGE
IN A MATRILINEAL SOCIETY IN THE COMORO ISLANDS

ROBERT PARKIN

The best known example of oblique marriage, i.e. marriage between an ego and an alter in adjacent genealogical levels,¹ involves the marriage of a man with his ZD, to whom he himself is MB.² There are a number of discussions of this phenomenon (Rivière 1969, Lavé 1966, Good 1980; also Parkin 1997: 106-8), but in general it is probably best interpreted as a variant of bilateral cross-cousin marriage in which a man takes his ZD as a wife not for his son but for himself. One property of the model is that, assuming lineage exogamy, such marriages are ruled out where there is matrilineal descent, as ZD and MB would then be in the same matrilineage (e.g. Good 1981). Accordingly the model of such systems is usually constructed in patrilineal, even where descent in the society concerned may be cognatic. However, a recent work by Ian Walker on the island of Ngazidja in the Comoro Islands shows how a similar model can be constructed in matrilineal (2010: 122, Fig. 3.11). As this has some theoretical interest, I am adding a few notes of my own on it here.³

Walker calls this arrangement, known as *mirande*, ‘an explicitly recognized strategy’ of spouse exchange between matrilineages (ibid.: 120), though it is far from being the only marriage strategy on Ngazidja (see ibid.: 116ff.). That is, marriages take place between matrilineages or *daho*, but normally *within* the higher-order *hinya* (matriclan). Some marriages take place within the *daho*, i.e. to classificatory MZD, especially, it seems, within ruling and other high-status *daho*, in order to keep the *daho* ‘pure’ and perhaps also to retain wealth and power within it. Such marriages give rise to some disquiet, though their motives are well understood (Walker ibid.: 117). As for *hinya* endogamy, this may be linked to the fact that *hinya* are ranked (Iain Walker, personal communication) and are therefore concerned not to undermine their ranking by entering into unsuitable alliances with other *hinya*.

¹ I use the term ‘genealogical level’ rather than ‘generation’ in this context, as the latter suggests individuals linked by age rather than by positions on a genealogical grid. This distinction is crucial to Rivière’s discussion of Trio marriage (1969: Ch. 7); see note 6 below.

² Abbreviations for kin specifications as at Parkin 1997: 9, List I.

³ I am grateful to Dr Walker for his comments on this note, as well as for his permission to use a figure in his book (Fig. 3.11 on p. 122) as the basis for my own diagram below.

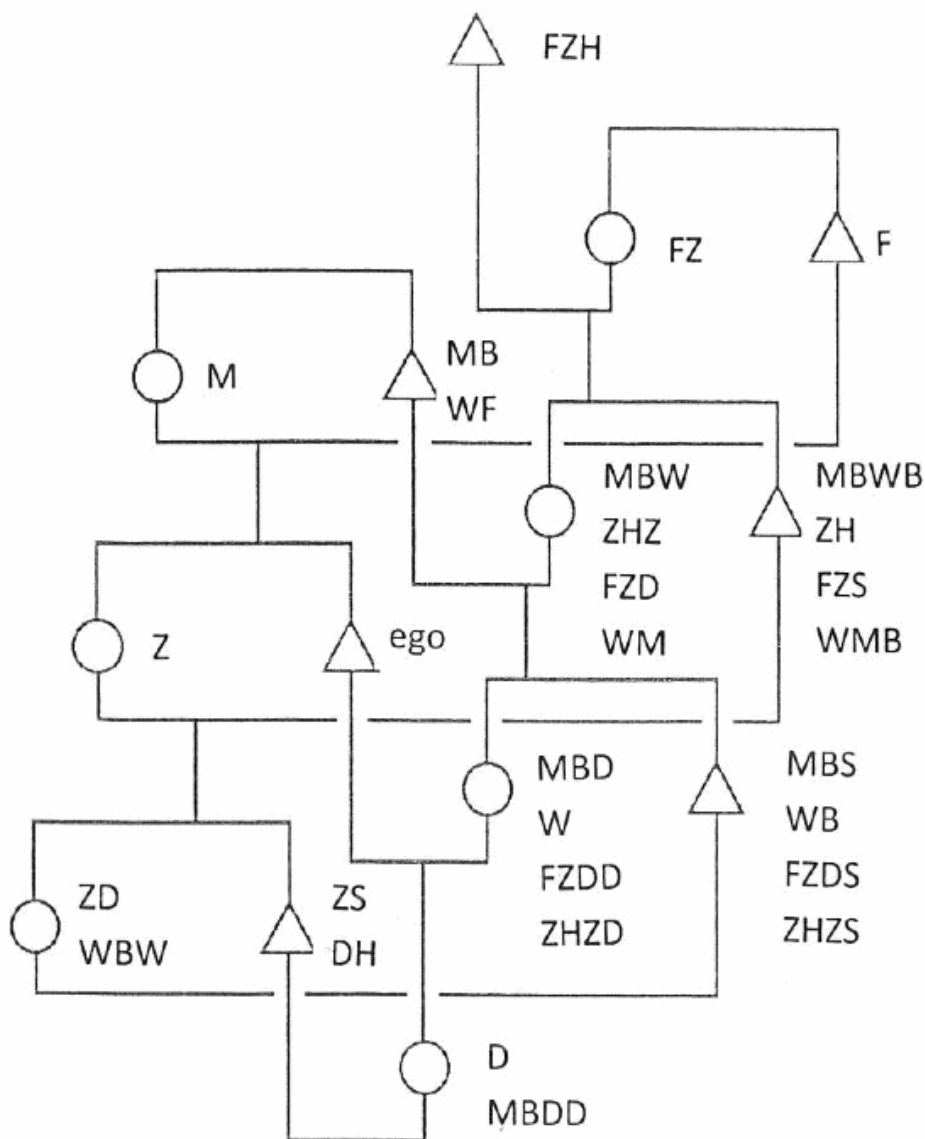

Figure 1. Hypothetical scheme of repeated *mirande* marriage (after Walker 2010: 122, Fig. 3.11, with permission)

In *mirande*, ZD marries not male ego (her MB), as in the model in patriline, but male ego's WB. This nonetheless means that those getting married are in adjacent genealogical levels and stand in the relationship of MBWB and ZHZD to one another. In addition, ego's daughter will marry ego's ZS, the pair being FZS and MBD to one another, that is, they belong to the same genealogical level. However, given the generational skewing of the diagram, FZS actually occupies the same position as MBWB (the latter being a genealogical level higher), MBD the same position as ZHZD (the latter being a genealogical level lower), though WB, ZS, ZD and daughter all occupy separate positions. *Mirande* is thus an exchange

of wives between two matrilineages: male ego gives his ZD, a woman of his own lineage, to his WB, who also occupies the position of MBS and is a member of the other lineage. Ego's daughter is also a member of the latter, while ZS is a member of ego's lineage: their marriage therefore completes the exchange.⁴

The fact that male ego can also be seen as marrying his MBD, since she occupies the same position as ZHZD and is in the other lineage, itself conforms to a common pattern in this society. Walker begins by describing this as MBD marriage (ibid.: 117), with lateral but no generational skewing, though like *mirande* it turns out to be explicable as a system of direct exchange, in which both male and female egos actually marry their bilateral cross cousins (ibid.: 118). From the indigenous point of view this permits such marriages to be construed as patrilateral rather than as matrilateral. Indeed, on Ngazidja all marriages are seen as patrilateral wherever possible, in defiance, almost, of the matrilineal aspects of kin ties here. Walker's reasons for this (ibid.: 118-20) are: 1) a desire to avoid drawing attention to the matrilineal and matrilateral aspects of kinship in an Islamic society ideally seen as stressing patriarchy, male links, inheritance through men, etc.; and 2) a need for particular individuals to circumvent the consequences of past slave descent by stressing their ties through men (given that female slaves and their uterine descendants lack matrilineages). It is the generational skewing involved in *mirande* marriages between MBWB and ZHZD that breaks this structural equivalence between MBC and FZC, who become equated with some of ego's -1 and +1 relatives respectively instead.

The model of *mirande* marriage has been worked out (by Walker) on the basis of a formal genealogical diagram constructed around the repetition of such marriages, not from the kinship terminology.⁵ However, it is clearly not a formal system repeated generation after generation, despite what the multi-generational model of it assumes (cf. the hypothetical Fig. 1 above), and it cannot be considered prescriptive. Indeed, Walker says that '*mirande* is particularly difficult to sustain beyond a single pair of marriages' (ibid.: 122). This is one difference from cases of ZD marriage between patriline or within cognatic groups, which are

⁴ One motive for the marriages involving ego's WB is that they are supposed to resolve some of the tensions that otherwise exist between ego and his WB (ego being the latter's ZH). WB is a member, perhaps the key member, of ego's affinal lineage, to which ego owes exchange obligations more generally (Iain Walker, personal communication).

⁵ The terminology presented and discussed by Blanchy (1992) does not appear to have any features that could be construed as an expression of the *mirande* system per se, though the term *mdjomba*, basically MB, can evidently also be used to address FZH (ibid.: 18); this is the only equation that bears any relationship to a system of bilateral cross-cousin marriage. Otherwise the Ngazidja terminology appears to be typically Bantu in form, with a lot of descriptive phrases for particular positions. Blanchy does not mention oblique marriages but in other respects confirms the account given by Walker, to whom I gratefully owe this reference.

seemingly easily made continuous or repeatable; Good (1980) even suggests that they are the standard form of marriage in south India, and Rivière intimates that the same can be said of the Trio in South America, depending on one's perspective (1969: 158).⁶ One of the limitations in the Ngazidja case is evidently that the more hierarchical aspects of society tend to undermine reciprocal spouse exchanges that suggest equality between *daho*, these aspects being absent, for different reasons, from both south India and South America. Another characteristic in the present case is that, through these arrangements, male egos have the right to bestow not only their own daughters but their sister's daughters on other men in marriage. Also, the very fact that ego's ZD marries ego's WB suggests that ego himself already is or has been married, as WB is, of course, his affine. Forms of marriage that depend on the existence of an earlier marriage are rarely predominant, though they may be framed in this way from either the indigenous or the observer's perspective (e.g. GEG marriages among certain Munda, Parkin 1992: Ch. 8; the Omaha, Barnes 1984).⁷

Clearly people on Ngazidja have more than one form of marriage available to them. Walker addresses this issue (*ibid.*: 122-3) by comparing the Ngazidja situation with Leach's famous study of the Kachin and their alternation between the *gumsa* and *gumlao* systems of affinal alliance (1954). Another example is Parry's study of kinship among Rajputs in north-east India (1979), similarly with two basic forms of marriage, one between alliance partners who are status equals, the other between those who are ranked. In both cases there are cyclical processes that link the two forms but also lead to their alternation because in some periods the desire for equality predominates, only to be pulled down by a reassertion of the hierarchical aspects of kinship, whether expressed as chiefly power (the Kachin) or as status within the caste (Rajputs; see also Parkin 2001: Ch. 14). It would be interesting to know if this could also be said of the various forms of marriage on Ngazidja, not least because here too there is evidently a tension between the principles of hierarchy (ranking) and equality in choosing alliance partners.⁸

⁶ In Rivière's own words (*ibid.*), 'ideally there are no oblique marriages, in terms of generation [i.e. defined by age, RP] there are few, terminologically all conventional alliances are oblique [i.e. between genealogical levels, RP], and in practice it is only marriage with the sister's daughter which takes place between genealogical levels.' Oblique marriages of different kinds (e.g. FZ/BD) have also been reported occasionally among indigenous populations in North America and elsewhere in the world.

⁷ There is a similar but not identical rather makeshift system in Papua New Guinea, namely the Daribi, who are patrilineal, not matrilineal; see my other note in this issue, also Wagner 1969.

⁸ Other forms of oblique marriages as subsidiary forms of marriage are also recorded among the Iatmul of Papua New Guinea (FMBD/FZSS) and some Mara of Australia (FMBD/FZSS, MBSD/FFZS and FFZD/MBSS); see Korn 1973: 89, after Geoffrey Bateson; *ibid.*: 119, after Lauriston Sharp.

Oblique marriages are rare cross-culturally, and it is uncertain whether they are ever the only form of marriage in the society concerned. *Mirande* marriage clearly conforms to this comparative finding. A matrilineal example is extremely unusual, however, and indeed I cannot think of another example anywhere in the world.

REFERENCES

- Barnes, R.H. 1984. *Two Crows denies it: a history of controversy in Omaha sociology*, Lincoln and London: University of Nebraska Press.
- Blanchy, Sophie 1992. Famille et parenté dans l'archipel des Comores, *Journal des Africanistes* 62/1, 7-53.
- Good, Anthony 1980. Elder sister's daughter's marriage in South Asia, *Journal of Anthropological Research* 36, 474-500.
- 1981. Prescription, preference and practice: marriage patterns among the Kondaiyankottai Maravar of south India, *Man* 16, 108-29.
- Korn, Francis 1973. *Elementary structures reconsidered: Lévi-Strauss on kinship*, London: Tavistock Publications.
- Lavé, Jean 1966. A formal analysis of preferential marriage with the sister's daughter, *Man* 1, 185-200.
- Leach, Edmund 1954. *Political systems of highland Burma*, London etc.: Athlone Press.
- Parkin, Robert 1992. *The Munda of central India: an account of their social organization*, Delhi etc.: Oxford University Press.
- 1997. *Kinship: an introduction to basic concepts*, Oxford and Malden: Blackwell.
- 2001. *Perilous transactions and other papers in Indian and general anthropology*, Bhubaneswar: Sikshasandhan.
- Parry, Jonathan 1979. *Caste and kinship in Kangra*, London: Routledge & Kegan Paul.
- Rivière, Peter 1969. *Marriage among the Trio: a principle of social organisation*, Oxford: Clarendon Press.
- Wagner, Roy 1969. Marriage among the Daribi, in R.M. Glasse and M.J. Meggitt, *Pigs, pearlshells, and women: marriage in the New Guinea Highlands*, Englewood Cliffs: Prentice Hall.
- Walker, Iain 2010. *Becoming the other, being oneself: constructing identities in a connected world*, Cambridge: Cambridge Scholars Publishing.